

Operating instructions

RondoDry rotary dryer



We are Fliegl.



**Read these operating instructions prior to first-time start-up and
observe them at all times!
Retain for future reference!**

Foreword

Dear valued customer,

Thank you for purchasing the Fliegl RondoDry.

Fliegl machines and attachments are manufactured with care under continuous monitoring. The Fliegl RondoDry you have purchased is a product manufactured to the highest quality standards.

To avoid accidents, and therefore personal injuries and material damage, you must read and understand the corresponding cautionary and warning notices in these operating instructions and on the Fliegl RondoDry before beginning operation or maintenance of the machine. These operating instructions must therefore also be passed on to the operating personnel.

Before putting the Fliegl RondoDry into operation, every operator must be familiar with how to handle the machine as described in these operating instructions. The safety requirements must be strictly followed. Compliance with safety regulations applicable to your country is also mandatory.

The limits of use are described in this manual. Any types of operation or use other than those described in these operating instructions, or beyond the limits of use specified by the manufacturer, are strictly prohibited.

Contents

Foreword	2
Contents	3
Legal notices	7
Identification	8
EC Declaration of Conformity	9
1. User instructions	10
1.1 Purpose of this document.....	10
1.2 Locations in the operating instructions	11
1.3 Illustrations used.....	11
1.4 Cross references	11
1.5 Terminology: "machine".....	11
1.6 Figures.....	11
1.7 Scope of the document	12
1.8 Presentation of safety instructions	12
1.9 Liability and damages.....	12
1.10 Duty to inform	12
2. Basic safety instructions.....	13
2.1 Designated use.....	14
2.2 Reasonably foreseeable misuse	15
2.3 Service life of the machine	15
2.4 Risks when working with the machine.....	16
2.5 Residual risks	16
2.6 Obligations of the operator	16
2.7 Obligations of personnel.....	16
2.8 Qualification of operating personnel.....	17
2.9 Qualification of specialist personnel	17
2.10 Personal protective equipment.....	17
2.11 Operational safety	18
2.11.1 Operation without correct start-up	18
2.11.2 Safeguarding perfect technical condition.....	18
2.11.3 Danger due to machine damage	18
2.11.4 Technical limits	18
2.12 Safety and protective devices	19
2.12.1 Emergency stop device	19
2.12.2 Description of additional safety and protective devices.....	19
2.12.3 Warning signals	19
2.12.4 Electrical connection.....	19
2.12.5 Inspecting safety and protective devices.....	20

Contents

2.13	Workstation of operating personnel	20
2.14	Danger areas	21
2.15	Machine identification	22
3.	Description of the machine	24
3.1	Applications	24
3.2	Functional description	24
3.2.1	Definition	25
3.3	Description of the main components	25
3.3.1	Integrated air heater unit "HeatBox" (standard)	25
3.3.2	Heating module (standard)	25
3.3.3	Dry chamber, tank, grid (standard)	25
3.3.4	Flushing pump (standard)	25
3.3.5	Sensors and control system (standard)	26
3.3.6	Equipment	27
3.3.7	Interfaces	27
3.4	Layout of the machine	29
3.5	Technical data for the main components and performance data	33
4.	Transport and installation	34
4.1	Transporting the machine to the installation location	34
4.1.1	Means of transport	34
4.1.2	Before transport	34
4.1.3	Transporting the machine	34
4.2	Setting up and assembling the machine	35
4.2.1	Setup	35
4.2.2	Assembly	35
5.	Supply and installation	36
5.1	Overview of installations	36
5.2	Establishing electrical connections	36
5.2.1	Procedure	36
5.2.2	Connecting the components	36
5.2.3	Electrical connections	36
5.3	Water installation	37
5.3.1	Procedure	37
6.	Start-up	38
6.1	First-time start-up	38
6.2	Check before start-up	38
6.3	Returning to service	38
6.4	Specifications for fault-free operation of the RondoDry	38
7.	Preparation and setup	39
7.1	Electrical system	39

7.2	Before operation	39
8.	Use and operation	40
8.1	Before operation	40
8.2	Switching on the machine	40
8.3	Conducting a trial run	40
8.3.1	Objective.....	40
8.3.2	Prerequisites.....	41
8.3.3	Procedure	41
8.4	Machine operation – procedure.....	41
8.5	Switching off the machine	41
8.6	Working with the machine	42
8.6.1	General safety and operating instructions.....	42
9.	Control and display elements.....	43
9.1	Location of the control and display elements	43
9.2	Operating elements on the switch cabinet	43
9.2.1	Mains isolator	43
9.2.2	Operating element: PLC machine control unit	43
10.	Equipment	44
10.1	Overview of the RondoDry	44
10.2	Additional components	44
11.	Service and maintenance.....	45
11.1	Customer service.....	45
11.2	Replacement parts	45
11.3	Type plate.....	46
11.4	Operational maintenance	47
11.4.1	General instructions for maintenance.....	47
11.4.2	Check the safety devices.....	47
11.4.3	Function test of the emergency stop equipment	48
11.4.4	Clean the machine.....	48
11.4.5	Lubrication schedule.....	49
11.4.6	Tightening torques for screw joints.....	49
11.4.7	Opening the folding frame of the HeatBox	50
12.	Troubleshooting and fault elimination.....	51
12.1	List of warning and fault signals	51
12.2	Control unit activation not possible.....	51
12.3	Start activation not possible	51
12.4	Decommissioning	52
12.4.1	Temporary shutdown	52
12.4.2	Storage conditions.....	52
12.4.3	Disassembly and final shutdown	52

Contents

12.4.4	Scrapping and recycling.....	52
13.	Additional documentation	53
13.1	Supplier documentation	53
13.1.1	List of document contents	53
13.2	PLC control unit	53
14.	Appendix	54
14.1	Conversion table	54

Legal notices

1. When the RondoDry is delivered, check immediately to determine whether the machine is complete. State any complaints to the freight forwarder, have them certified on the delivery documents and inform the delivering plant within 14 days after you become aware of the problem (see "Scope of delivery").
2. The manufacturer is liable for technical defects. The owner is liable for defects that were caused by improper operation. The warranty period is 1 year from delivery.
3. At our discretion, the warranty will either cover the cost of repair of the faulty part or replacement of the part, or delivery of the part from the factory, carriage due. Any other claims for compensation (such as for losses due to business interruption) are expressly excluded.
4. The warranty will be invalidated if the attachment or device is modified by installing third-party parts without our knowledge or prior agreement, especially if improper modifications were made.
5. The warranty will also be invalidated if a defect is not rectified completely and correctly immediately after it is discovered. Repairs required for functional reasons need our prior approval if a claim is to be made for full or partial compensation of expenses.
6. Liability is excluded for damage to the RondoDry resulting from exceeding the allowable working capacity. The warranty does not cover natural wear, damage resulting from negligent or improper handling of the machine, or storage and corrosion damage.
7. Parts not manufactured by us are covered by the warranty provided by the relevant manufacturer. Machine parts for which claims are made under the terms of the warranty must be sent without delay to our address in Mühldorf for the purpose of material examination to determine the damage. If a replacement is made, these parts become our property.
8. Legal warranty provisions also apply to the Fliegl RondoDry.

Identification

Machine identification data

Manufacturer:	Fliegl Agrartechnik GmbH
Product:	RondoDry
Type:	Rotary dryer
Serial number:	F XXXX

Manufacturer details

Fliegl Agrartechnik GmbH
Bürgermeister-Boch-Straße 1
84453 Mühldorf am Inn, Germany

Tel.: +49 (0)8631 307 - 0

Fax: +49 (0)8631 307 - 550

E-mail: info@fliegl.com

Website: www.fliegl.com

Formal details of operating instructions

Document no.:	2-100B06212.1
Version/revision:	2.1
Creation date:	10/08/2016
Last revision:	08/07/2021



Language of original operating instructions: German
(Translation of original operating instructions)

© Copyright Fliegl, 2021 All rights reserved.

Reproduction, in whole or in part, is only permitted with the approval of Fliegl.

We are constantly developing and enhancing our products and therefore reserve the right to make changes to them without prior notification.

This may result in differences in the illustrations and descriptions in these operating instructions.

EC Declaration of Conformity

As stipulated in EC Machinery Directive 2006/42/EC, Annex II, 1.A (ORIGINAL)

Manufacturer:
Fliegl Agrartechnik GmbH
Bürgermeister-Boch-Straße 1
84453 Mühldorf am Inn, Germany

**Person residing in the European Community
who is authorised to compile the relevant
technical documentation:**

Josef Fliegl jun.
Fliegl Agrartechnik GmbH
Bürgermeister-Boch-Straße
84453 Mühldorf am Inn, Germany

Machine description and identification:

Product: RONDODRY
Trade name: Rotary dryer
Function: Drying system

It is expressly stated that this machine complies with all relevant provisions of the following EC directives:

2006/42/EC	EC Machinery Directive 2006/42/EC
2000/14/EC	Directive 2000/14/EC of the European Parliament and of the Council of 8 May 2000 on the approximation of the laws of the Member States relating to the noise emission in the environment by equipment for use outdoors.
2014/35/EU	Directive 2014/35/EU of the European Parliament and of the Council of 26 February 2014 on the harmonisation of the laws of the Member States relating to the making available on the market of electrical equipment designed for use within certain voltage limits.
2004/108/EC	Directive 2004/108/EC of the European Parliament and of the Council of 15 December 2004 on the approximation of the laws of the Member States relating to electromagnetic compatibility and repealing Directive 89/336/EEC.

Source of the harmonised standards applied in accordance with Article 7(2):

EN ISO 12100:2011-03	Safety of machinery – General principles for design – Risk assessment and risk reduction (ISO12 100:2010)
DIN EN 349:2008-09	Safety of machinery – Minimum gaps to avoid crushing of parts of the human body
DIN EN ISO 14120:2016-05	Safety of machinery – Guards – General requirements for the design and construction of fixed and movable guards (ISO 14120:2015)
EN 614-1:2009-06	Safety of machinery – Ergonomic design principles – Part 1: Terminology and general principles
EN 50491-5-3:2010-11	General requirements for home and building electronic systems (HBES) and building automation and control systems (BACS) – Part 5-3: EMC requirements for HBES/BACS used in industry environment
EN 50491-5-1:2010-11	General requirements for home and building electronic systems (HBES) and building automation and control systems (BACS) – Part 5-1: EMC requirements, conditions and test set-up
EN 61310-2:2008-09	Safety of machinery – Indication, marking and actuation – Part 2: Requirements for marking
EN 61310-3:2008-09	Safety of machinery – Indication, marking and actuation – Part 3: Requirements for the location and operation of actuators

Mühldorf am Inn
Place,

08/07/2021
Date



Fliegl Agrartechnik GmbH
Bürgermeister-Boch-Str. 1
D-84453 Mühldorf a. Inn
Tel. +49 (0) 8631 307-0
Fax +49 (0) 8631 307-550
Josef Fliegl jun., Geschäftsführer

1. User instructions

This manual provides information about the:

- Structure
- Function
- Operation
- Maintenance
- Accessory parts

of the RondoDry and ensures long, problem-free operation if it is carefully observed.

In case of malfunctions, it can be used to troubleshoot and rectify errors.

The purpose of the safety instructions is to prevent personal injury and damage to the RondoDry.

All operators are required to read these safety instructions and comply with them at all times.

The regulations of agricultural employers' liability insurance associations also apply.

Fliegl assumes no liability and honours no warranty for damage and malfunctions resulting from failure to comply with the operating instructions.

This information is required to ensure a smooth replacement parts ordering process:

Copy the relevant information from the type plate into the box below:

Machine ID no. (serial number)
Type
Year of manufacture

Contact for replacement part orders:

Fliegl Dosiertechnik GmbH
 Bürgermeister-Boch-Straße 1
 84453 Mühldorf am Inn, Germany
 Tel.: +49 (0)8631 / 307 - 354
 Mobile: +49 (0)178 / 200 88 01
 E-mail: biogas@fliegl.de
www.fliegl.de



Replacement parts must satisfy the technical requirements stipulated by the machine manufacturer as a minimum.
 This requirement is always met when using Fliegl original replacement parts.

1.1 Purpose of this document

These operating instructions:

- Describe the function, operation and maintenance of the machine.
- Provide important advice for safe and efficient handling of the machine.

1.2 Locations in the operating instructions

All directions and locations in these instructions are based on the operator's workstation.

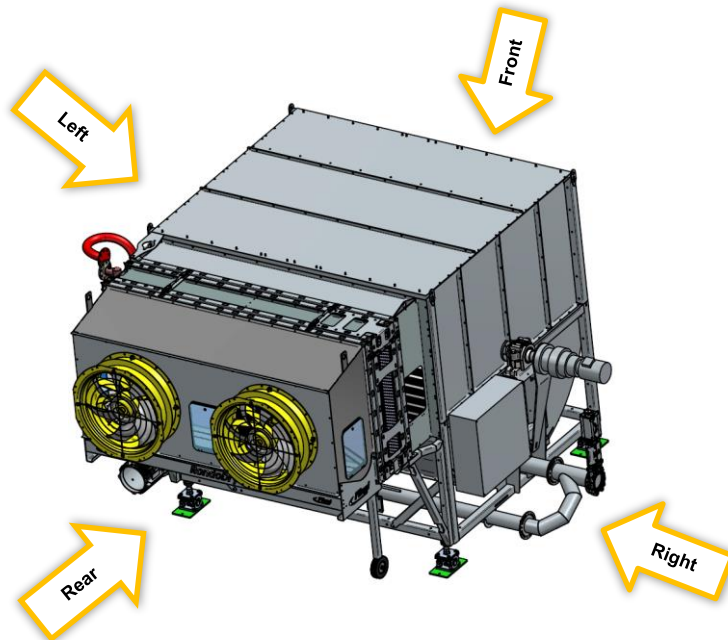

Fig. 1: Locations in the documentation

1.3 Illustrations used

Instructions and system responses

The steps to be taken by operating personnel are presented in the form of a (numbered) list. These steps must be followed in the correct order. The system response to each operator action is marked with an arrow. Example:

Operator action step 1

→ System response to operator action step 1

1.4 Cross references

Cross references to other points in the operating instructions appear in the text along with the relevant chapter and subchapter or section.

1.5 Terminology: "machine"

Within this document, the RondoDry is also referred to as the "machine".

1.6 Figures

The figures in this document do not always depict the exact machine type. The information relating to the figures always corresponds to the machine type described in this document.

1.7 Scope of the document

In addition to the standard models, B variants of the machine are also described in this document. Your machine may deviate from this.

1.8 Presentation of safety instructions



Danger! Imminent risk that will lead to serious bodily harm or death.



Warning! Potentially hazardous situation that could lead to serious bodily harm or death.

Caution! Potentially hazardous situation that could lead to minor bodily harm. Also warns against potential damage to property.



Notice! Potentially harmful situation in which the product or other property in its vicinity could be damaged.



Important! For usage instructions and other helpful information.

1.9 Liability and damages

The product must only be operated by persons who are familiar with the operating instructions, the product and national laws, directives and regulations relating to health and safety at work as well as accident prevention. We accept no liability for personal or material damage caused, or contributed to, by untrained persons due to non-compliance with regulations regarding health and safety at work as well as accident prevention.

Based on the specifications in these operating instructions, Fliegl Agrartechnik GmbH assumes no liability for direct or consequential damage attributable to improper operation or maintenance.

For your own safety, you should only use original replacement parts and accessory products.

Fliegl Agrartechnik GmbH assumes no liability for the use of other products and any resulting damage.

No claims for modification of delivered products can be made on the basis of the information, images and descriptions provided in this manual.

1.10 Duty to inform

These operating instructions are to be considered part of the RondoDry. If the machine is passed on to another party by the customer, the operating instructions must also be passed on and the party receiving the machine must be instructed regarding the regulations cited above.

Only the procedures described in these operating instructions are safe.

- Read and observe the contents of chapter 2 Basic safety instructions before first using the machine.
- Before performing any work with the machine, always read and observe the contents of the relevant sections of the operating instructions.
- The operating instructions must be stored such that they are always on hand for the machine user.

2. Basic safety instructions



Failure to observe the safety instructions and warnings can pose a risk to persons, property and the environment.



- Risk of injury to upper limbs due to accidental contact with the shaft in the pedestal bearing and on the gear motor.
- Risk of fatal electric shock in the area of the switch cabinet, cable guides and cable joints.



- High risk of poisoning due to production of ammonia gases when drying the digestate.



- In the event of any faults that affect safety, the machine must be stopped immediately.
- The machine must be secured against reactivation!



- Repairs, servicing and maintenance work must only be performed when the system is de-energised.
- The mains isolator switch must be **OFF** and secured against reactivation.



- The personnel setting up the machine must be specially trained and must be wearing personal protective equipment. All safety instructions are provided in the operating instructions.
- For transport, a suitable carrier vehicle must be used with appropriate transport chains and hooks.
- In addition, the personnel responsible for start-up, maintenance, repairs and decommissioning must always wear personal protective equipment.



- High injury risk for persons in the surrounding area due to the rotation of the drum with the pressure grids in the dry chamber.
- Check the machine after use every day for obvious damage and defects.
- In the case of damage that affects safety, have the machine repaired immediately.



- Changes to the RondoDry must only be carried out following consultation and with express permission of the manufacturer.
- Use only original replacement parts.
- Follow the maintenance intervals stipulated in this manual.
- In addition to this manual, the supplied operating instructions for the third-party components and control unit must be observed.

2.1 Designated use

The machine is constructed according to the EC Machinery Directive using the latest technology and in accordance with the recognised safety regulations. However, during use there is a risk to life and limb for the user or third party, or risk of damage to the machine or other property.



Danger!

The RondoDry must only be used as intended and when in good and safe working condition. Operational safety of the machine is guaranteed only if it is used as intended.

The Fliegl RondoDry was developed for drying (thickening) of slurry or liquid digestate from biogas plants (more details are provided in section 3.2.1). Slurry or digestate is taken either from the slurry pit, the final repository of a biogas plant or an upstream container. Use of the machine with substances that are hazardous to water is subject to the country-specific laws and regulations.

If the Fliegl RondoDry is used to dry liquids other than slurry and digestate, the relevant liquid must be classified by the customer with regard to its potential impact on water as a result of escaping liquid. Consequently, the customer is responsible for observing and implementing all protective measures resulting from requirements of the ground surface, of the water-retaining capacity or relating to infrastructural measures of an organisational or technical nature.

If the RondoDry is sold outside Germany, the aforementioned provisions must be applied for the applicable comparable national and or/local regulations.

Overfilling the machine with material can result in damage to the machine, for which *Fliegl Energy GmbH* shall assume no liability.

The machine must only be used to dry slurry and digestate.

The machine was developed solely for agricultural use and must only be used if:

- All safety equipment specified in the operating instruction is present and in the safety position
- All safety instructions in the operating instructions are observed and complied with, including the information in the chapter "Basic safety instructions" as well as the specific instructions in the individual chapters

The operating instructions form part of the machine and must remain with the machine at all times. The machine must only be operated following appropriate instruction and in strict compliance with these operating instructions.

Any use of the machine not described in the operating instructions can result in serious injury or death and may also lead to machine and property damage.

Unauthorised changes to the machine can have a negative impact on the machine properties or impair its correct function. Unauthorised changes will therefore release the manufacturer from any resulting liability.

Designated use also includes compliance with the operating, maintenance, cleaning and repair instructions prescribed by the manufacturer.

2.2 Reasonably foreseeable misuse

Any use other than the defined "designated use" or any use which exceeds this shall be defined as misuse. *The manufacturer/supplier accepts no liability for any resulting damage.*



Misuse can be dangerous.

Examples of such misuse are:

- Drying of inorganic substances such as industrial sludge or chemical effluent or of liquids with dissolved salts.
- Operation of the machine in explosive atmospheres and in closed rooms.
- Exceeding of the technical values defined for normal operation.
- Failure to observe safety stickers on the machine and safety information in the operating instructions.
- Performing troubleshooting, adjustments, cleaning, repairs and maintenance contrary to the specifications in the operating instruction.
- Unauthorised changes to the machine.
- Attachment of additional equipment that has not been authorised or approved.
- Use of non-original FLIEGL replacement parts.

Modifications and changes

Any unauthorised modifications and changes to the machine (such as welding onto bearing parts) *will void all liabilities and the manufacturer's warranty.*

Additions or modifications of any kind can affect the electro-magnetic behaviour of the machine. Therefore, do not make any changes or add anything to the machine without consulting and receiving written agreement from the manufacturer.

Replacement and wear parts and auxiliary materials

The use of replacement and wear parts or auxiliary materials from third parties can lead to dangers. The manufacturer accepts no liability for damage resulting from the use of these parts. Therefore, use only original parts or parts approved by the manufacturer.

2.3 Service life of the machine

- The service life of this machine greatly depends on its correct use and maintenance as well as the specific applications and operating conditions.
- Following the instructions and information in these operating instructions will safeguard the operational readiness of the machine and maximise its service life.
- The individual components must be maintained at regular intervals as per table 11.4.1.
- After each season of use, the machine must be checked thoroughly for signs of wear and other damage.
- Damaged or worn parts must be replaced before any subsequent use of the machine.
- Following a prescribed, type-specific period of use, the machine must be subjected to a comprehensive technical inspection. A decision as to the continued use of the machine must then be made based on the results of this inspection.
- The service life of the machine is theoretically unlimited since all worn or damaged parts can be replaced.

2.4 Risks when working with the machine

Risks and impairments can arise when using the machine. These may take the form of risks to life and limb of the operator or third parties as well as:

- Risks for the machine itself
- Risks for other material assets

Safe and fault-free operation of the machine requires knowledge of the safety and user instructions set out in this manual.



Always store the operating instructions at the usage location of the machine. The operating instructions must be available to operators and maintenance personnel. Also be aware of the following:
General and location-specific regulations regarding accident prevention and environmental protection.

2.5 Residual risks

The machine is built according to the state of the art and recognised safety rules.

However, during use there is a risk to life and limb for the user or third party, or risk of damage to the machine or other property.

In addition to the manufacturer's countermeasures against dangers caused by residual energy, the operator must also take appropriate countermeasures. Personnel must be briefed about these dangers and the measures to be taken to prevent them.

2.6 Obligations of the operator

The operating company is required to instruct its personnel regarding:

- Basic regulations regarding work safety and accident prevention
- Correct operation of the machine
- The operating instructions (ensure that personnel have read and understood them)

The operator is obligated to:

- Keep all hazard symbols on the machine in legible condition
- Replace any damaged or removed hazard symbols



The requirements of the EC Directive for the use of work equipment 89/655/EEC must be observed.

2.7 Obligations of personnel

Before starting work, all personnel tasked with working on the machine undertake to:

- Comply with the basic regulations regarding work safety and accident prevention
- Read and comply with the safety section and warnings in these operating instructions
- Please contact the manufacturer with any questions; see page 8.

2.8 Qualification of operating personnel

To avoid accidents, any person working with the machine must meet the following minimum requirements:

- He or she must be physically capable of controlling the machine.
- He or she can perform their work with the machine safely and in compliance with these operating instructions.
- He or she understands the function of the machine within the context of their duties and can recognise and avert the dangers arising from their work.

2.9 Qualification of specialist personnel

If the required work on the machine (assembly, alteration, conversion, extension, repairs, retrofits) is performed incorrectly, this can lead to serious injury or death. To avoid accidents, any person performing work in accordance with these operating instructions must meet the following minimum requirements:

- He or she is a qualified specialist with the appropriate training to perform the required work.
- Based on their technical expertise, he or she is able to assemble the (partially) disassembled machine as described in the manufacturer's assembly instructions.
- Based on their technical expertise, he or she is able to expand, alter or restore the function of the machine as prescribed in the relevant instructions of the manufacturer.
- He or she can perform the work described in these operating instructions in a safe manner.
- He or she understands the function of the required work as well as the machine and can recognise and avert the dangers arising from this work.
- He or she has read these operating instructions and can apply the information contained therein in an appropriate manner.



Maintenance and repair work indicated by this symbol must only be performed by a specialist workshop. The personnel of the specialist workshop must have the requisite knowledge and appropriate equipment (tools, lifting and supporting devices) to maintain and/or repair the machine in a safe and professional manner.



2.10 Personal protective equipment

The operating company must provide the following personal protective equipment.

- Safety footwear with protective toe caps
- Define and provide personal protective equipment for the relevant application.
- Only use personal protective equipment that is in flawless condition and offers effective protection.
- Safety and protective devices



The machine must only be operated if all safety and protective devices are complete and fully functional.

2.11 Operational safety

2.11.1 Operation without correct start-up

Without a correct start-up in accordance with these operating instructions (section 6), the operational safety of the machine is not guaranteed. This can result in accidents involving personal injury.

2.11.2 Safeguarding perfect technical condition

Incorrect maintenance and adjustments can impair the operational safety of the machine and lead to accidents involving personal injury.

- All maintenance and adjustment work must be performed as described in the relevant sections.
- Shut down and secure the machine before performing any maintenance and adjustment work.

2.11.3 Danger due to machine damage

Damage to the machine can impair its operational safety and lead to accidents involving personal injury. The following machine components are particularly safety-relevant:

- Fill level sensors
- Components of the folding frame
- Flange connections of the heating water supply
- Electrical supply to the switch cabinet
- Safety grid on the fans

In the case of doubts regarding the operational safety of the machine, e.g. due to leaking fluids or visible damage:

- Shut down the machine and secure it against reactivation.
- Eliminate potential causes of damage immediately
e.g. remove dirt and debris or tighten loose screws.
- Establish the cause of the damage as per these operating instructions.
- Repair the damage as per these operating instructions.
- In the case of damage that cannot be rectified independently based on these operating instructions:
 - Have the damage repaired by a qualified workshop.

2.11.4 Technical limits

If the technical limits of the machine are not maintained, this can lead to machine damage.

This can result in accidents involving personal injury.

Compliance with the technical limits specified in the individual sections of these operating instructions is particularly important from a safety perspective. A list of the technical data for the main components is provided in section 3.4.

2.12 Safety and protective devices

The following safety and protective devices are installed in the machine:

2.12.1 Emergency stop device

The EMERGENCY STOP must be operated in an emergency. With the emergency stop switch, only the drum motor and external contacts (e.g. pumps) are safely shut off. The fans continue running for safety reasons, as otherwise the concentration of hazardous gases (ammonia, hydrogen sulphide etc.) in the dryer and/or washer could increase. Operation of the heating circulation pump (if activated by the RondoDry) also continues since it only poses a minimal risk and deactivation could result in significant economic loss (due to frost).



Fig. 2: EMERGENCY STOP

The EMERGENCY OFF must be operated when:

- All risks (gases, frost) present in the first step have been eliminated, meaning that the RondoDry can be completely shut down
- Repair work must be performed (caution: do not access before venting the machine, risk of gases)
- Electrical lines begin to smoulder, for example



Fig. 3: EMERGENCY OFF

2.12.2 Description of additional safety and protective devices

The following safety devices are installed on the machine:





- Safety grid
- Guard plates
- Heat insulation
- Mains isolator



The machine must only be operated if all safety and protective devices are complete and fully functional.

2.12.3 Warning signals

Warning lamps and indicators:

- **RED** – emergency – immediate action 
- **YELLOW** – abnormal – monitoring/intervention 
- **GREEN** – normal – optional 
- **BLUE** – mandatory – required action 
- **WHITE** – neutral – monitoring 

2.12.4 Electrical connection

The electrical lines and connections must be installed in accordance with local provisions. The machine must only be equipped with the prescribed switch. The switch must be clearly labelled so that its function and assignment is easy to understand. The specifications are detailed in the following standards, for example:

- DIN EN 60204-1 – Electrical equipment of machines – Part 1
- DIN EN ISO 13850 – Emergency stop function – Principles for design

2.12.5 Inspecting safety and protective devices

All safety and protective devices must be checked regularly. Inspection intervals according to table:

Safety device	Check upon final acceptance	Monthly check
Check whether the pictograms are affixed to the attachment points	X	
Check whether function and screw joints are present and correct	X	
Check whether the grid on the axial fan is securely fastened	X	
Check that the protective cover on the gear motor is free of damage	X	X
Check whether cables are correctly routed	X	
Check all panel joints for leaks	X	X
Functional check of the EMERGENCY OFF switch	X	X
Functional check of all visual indicators	X	X
Check all insulating points of electrical lines and connectors	X	X
Leak test of the dry chamber	X	X
Check that all guard plates are secure and free of damage	X	X
Check that the counter plate lug of the electric motor is secure using a torque wrench	X	
Check the function of the overflow sensor.	X	
Check that all safety stickers are present and correct	X	X

2.13 Workstation of operating personnel

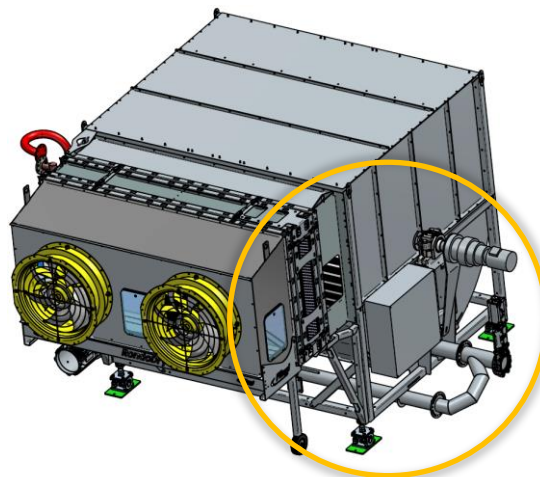

Fig. 4: Workstation of operating personnel (model may vary)

2.14 Danger areas

A danger zone exists around the machine when in use. To ensure that no persons enter this danger zone, the minimum safety distance must be observed.

If this safety distance is not maintained, this can result in accidents involving personal injury.

- Only switch on the machine if there are no persons within the danger zone.
- Cease operation immediately if persons enter the danger zone.

The minimum safety distances are as follows:

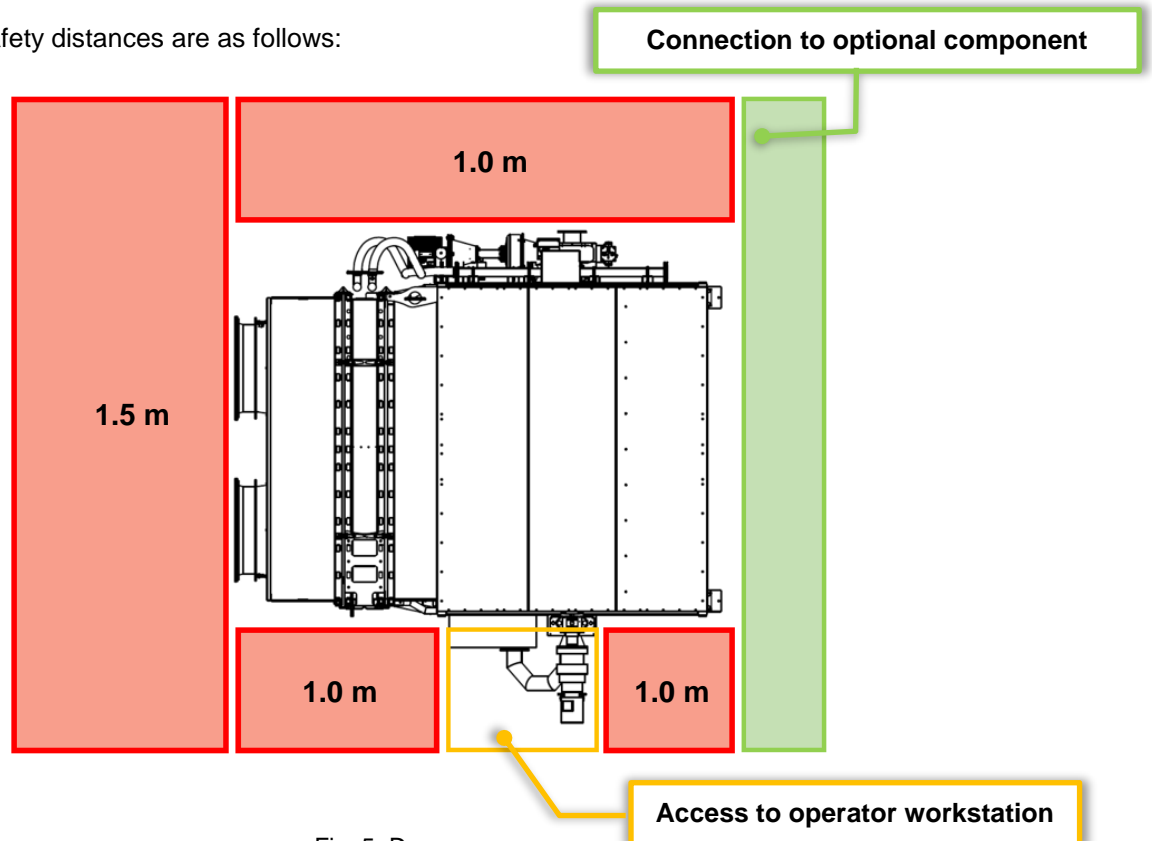

Fig. 5: Danger zone

The values specified above are minimum safety distances based on designated use of the machine. These values depend on the individual application and environmental conditions and must be increased where necessary – e.g. when opening the HeatBox. The machine must be shut down and secured for all work performed within the danger zone, including brief checks.

Other relevant specifications in all applicable operating instructions must be observed:

- The operating instructions of the machine
- The operating instructions of third-party components

2.15 Machine identification

There are warning signs on the machine to warn of the following residual dangers which cannot be eliminated:

<p>Notice regarding hazard symbols:</p> <ul style="list-style-type: none"> The hazard symbols must be kept clean and must not be concealed. Damaged or missing hazard symbols must be replaced. When attaching additional devices, add the corresponding hazard symbols if necessary. Consult the manufacturer where necessary. 		<p>Caution Exercise special caution when handling or touching</p>
		Warning against automatic restart
		Warning against hot surface
		Information in operating instructions Read contents of operating instructions before handling
		Warning of crushing risk on rotating rollers
		Warning of sharp edges (risk of cutting)
		Danger due to crushing or entanglement
		Attention! System starts automatically
		Earthing point
		The bearings must be re-lubricated on a continuous basis. Check the transmission oil level before starting. Re-tighten all screws.
		Final inspection Information sign for completed final inspection of machine
		Mandatory sign for lubricating points
		Mandatory sign for lifting points

Observe all *warnings and safety instructions* on the machine as well as other labelling such as turning and transport directions.

The following identifications are also located on the machine:



CE identification number
Indicates conformity with applicable EU directives related to the product, which also require a CE marking.
(Located on type plate.)

84453			
Mühdorf			
Fahr. Nr.	Fahrzeug ID-Nummer		
L mm	xxx	Länge mit / ohne Wärmetauscher	xxx
B mm	xxx	Breite innen / außen	xxx
H mm	xxx	Höhe innen / außen	xxx
Typ	RondoDry	Baujahr	xxxx
CE		AU-Nummer	

Type plate to specifically identify the machine.

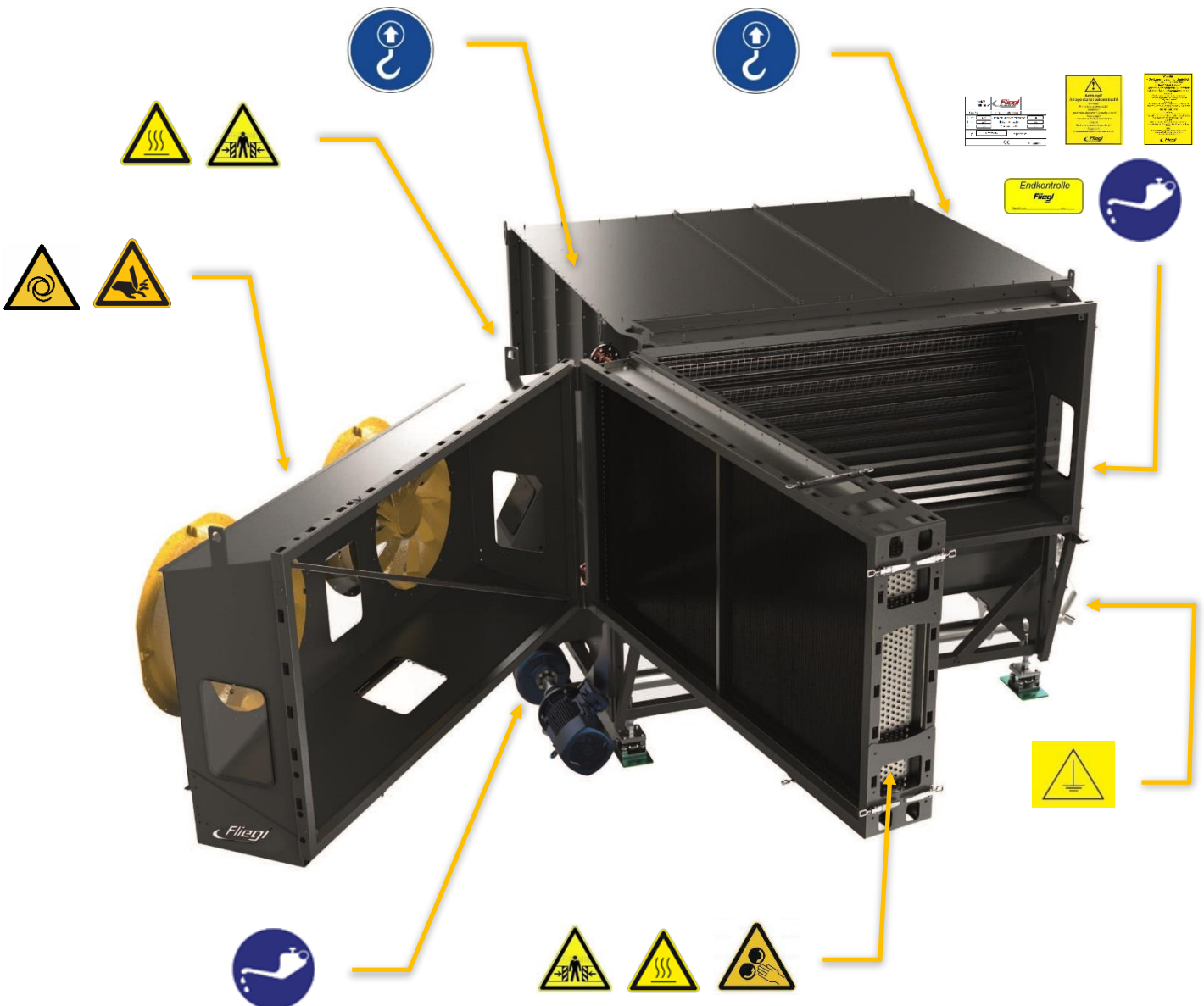

Fig. 6: Warnings and safety instructions affixed to the machine (model may vary)

3. Description of the machine

This section gives a complete overview of the layout and function of the machine.
If possible, read it at the machine. That is the best way for you to familiarise yourself with the machine.

3.1 Applications

Information is provided in section 2.1 "Designated use".

3.2 Functional description

The RondoDry drying system usually features an on-site, upstream separator for separating the rough solid particles. When used with digestate from biogas plants, the substrate must always be separated to ensure full functionality and maximum performance of the system.

If the system is used to dry substrates other than slurry and digestate or if, during project development, the operator is considering foregoing the separation process, this requires prior coordination with Fliegl's dosing and drying technology department.

The liquid to be thickened is transferred from an upstream container into the RondoDry by means of a suitable pump or flows by gravity. When the maximum fill level is reached, the pump switches off (if fitted) and the gate valve closes. The RondoDry is now filled.

Inside the RondoDry is a slow-rotating, cylindrical grid.

This grid consists of mesh elements, which are designed to offer a comparatively large surface area relative to the available volume. Once the RondoDry has been filled, the grid is submerged in the digestate by about a third, while the rest of the grid extends upwards out of the digestate, where it is exposed to the hot airflow.

When submerged in the digestate, the surface of the grid elements is coated with a thin layer of liquid. The hot airflow passes through the grid elements, thereby resulting in the evaporation of part of the liquid adhering to the grid.

The weight of the RondoDry and its contents is measured and logged by means of Fliegl weighing technology (load cells). Once the required evaporation quantity has been reached (target weight), the remaining liquid in the RondoDry is discharged via the pump. Following the discharge of a thickened load, the filling and thickening process restarts. Alternatively, the system can be controlled on the basis of maximum and minimum filling, evaporation and emptying times. The system operates in automated batch mode as standard. If required, the system can also be used in continuous mode.

The Fliegl heat management system regulates the thermal power output via the circulation pumps and fan speed. The RondoDry only uses the heat quantity that remains after the upstream consumers (fermenter heating, building, etc.) have been supplied. The RondoDry thus reduces the runtimes of the emergency cooler. The system functions as a residual heat consumer (cooler) on the secondary side (heating system side). Depending on the environmental conditions (intake air humidity, temperature, etc.), the RondoDry thermally evaporates up to 1 kg of water for each kilowatt hour with this process. The RondoDry is configured for a max. thermal power draw of 500 kW.

The maximum annual evaporation quantity is calculated on the basis of the "drying efficiency" of 1 kg H₂O for each kilowatt hour, the average thermal power consumption in kW and the annual operating hours. When the system is used with slurry or digestate, any ammonium nitrogen (NH₄-N) and odorous substances contained in the slurry are converted to gaseous state along with the water. To meet the emission limits and wash out the ammonia contained in the RondoDry exhaust air, thereby producing a valuable mineral fertiliser, the RondoDry usually feeds into an exhaust air scrubber, which binds the contained ammonia via sulphuric acid dosing, which in turn enables targeted separation and collection as an ammonium sulphate solution.

3.2.1 Definition

The Fliegl RondoDry is a system for thickening liquids which have a low solids content (< 5%, fibre length < 15 mm) and which contain valuable substances the retention of which in the materials cycle is of economic and ecological significance (generally slurry or digestate). In this context, the term "thickening" refers to concentration via water reduction. The evaporation of a specific quantity of water increases the level of dry matter in the treated liquid. The substrate is liquid, flowable and pumpable both before and after the thickening process.

3.3 Description of the main components

3.3.1 Integrated air heater unit "HeatBox" (standard)

Two axial fans create a hot air flow of max. 40,000 m³/h (depending on the available heat quantity), which is generated by a downstream water/air heat exchanger. The externally aspirated air flows through the heat exchanger and absorbs the provided heat. With the max. air flow of 40,000 m³/h, up to 500 kW of thermal power is made available for the thickening process (output power). The heat exchanger is designed to utilise the waste heat of a CHP plant or a boiler system with supply temperatures of up to 95°C. The HeatBox is connected to the RondoDry via a folding frame as standard. This allows the hot air heater unit to be folded to the side for maintenance and cleaning work.

3.3.2 Heating module (standard)

The heating module consists of the pre-assembled flow meter for the heat meter and the heating circulation pump. These heat management components are fully fitted and wired on the machine, and they are prepared for start-up and tested in the factory prior to delivery.

3.3.3 Dry chamber, tank, grid (standard)

Inside the RondoDry is a slow-rotating, cylindrical grid. This grid consists of mesh elements, which are designed to offer a comparatively large surface area (> 400 sqm) relative to their required space.

3.3.4 Flushing pump (standard)

Since sediment from the substrate can settle at the bottom of the dryer during the thickening process, a centrifugal pump is fitted as standard for flushing purposes. It flushes the dryer with substrate via a bypass fitted to the device, thereby suspending the sediment. After this "agitation", the substrate is pumped out along with the solid matter and sediment. The flushing pump also enables periodic cleaning of the dryer with fresh water (intervals dependent on substrate composition).

Description of the machine

3.3.5 Sensors and control system (standard)

Weighing system

The RondoDry features four digital load cells, each of which performs an individual weight measurement. By combining these measurements, the mass of the RondoDry can be determined and the fill quantity calculated based on the empty and actual weights. If an analysis of the input material exists, the dry mass content of the output material can be calculated on the basis of the weight loss.

Min. and max. fill level sensors

The sensors for the minimum and maximum fill level detect whether liquid is present. They thus enable time-based operation (max. and min. time monitoring) and ensure that the dryer is not overfilled and that the pump system does not run dry. Operation via the sensors requires that they be cleaned on a daily basis.

Storage tank fill level sensor

The sensor for the storage tank fill level detects whether material exists in the customer's storage tank. If material is present, the dryer is enabled. This protects the dryer and prevents the pump system from running dry.

Supply air sensor

The supply air temperature sensor is located in the blower box and determines the actual ambient temperature. If the temperature drops below the set threshold, the system switches to under-temperature protection (heating pump min. speed), provided that the RondoDry is not in automatic mode. Note: The operator bears sole responsibility for ensuring appropriate frost protection.

System temperature sensor

The system temperature sensor is located in the hot water return line downstream from the RondoDry heat exchanger. It is a central part of the heat management control system.

Overfill protection

The overfill protection prevents overfilling of the RondoDry.

System control

Manual and automatic mode for the RondoDry drying system, incl. alarm and data logging (RondoDry data) of the most important values for the dryer and air scrubber. Remote access option. Self-learning thanks to continuous overrun correction during filling, evaporation and emptying. Documentation of measured values for verification procedures (efficiency criterion) and recording of material flows:

- Leak-tightness of systems (change in weight over time; factory acceptance test)
- Change in weight over time: volume of reduced water during operation, documentation of total throughput
- Utilised heat quantity

Optional: transfer of measured values from the exhaust air scrubber

3.3.6 Equipment

Gate valves

Knife gate valve with pneumatic cylinder. Position feedback via reed contact and magnet. Including solenoid valve. Compressed air supply must be provided by the customer. When pressure is applied, the gate valve is closed when de-energised.

Eccentric screw pump

Used to fill and empty the RondoDry. Actuated via the "Greenbox" on-site control cabinet. The Greenbox contains all components for controlling and monitoring the pump, as well as for integration in the safety and emergency stop chain, even with a customer power supply.

Circulating pump (part of the heating module)

For providing heating water and maintaining the correct pressure. The pump is actuated via the RondoDry control system. Also controls fluctuating flow rates (e.g. in flex mode) thereby ensuring constant temperature levels.

Heat meter (part of the heating module)

Flow meter for determining the mass and volumetric flow rates of the heating water and temperature sensors for the supply and return before and after the RondoDry heat exchanger. Documents the utilised heat quantity and provides the temperature for regulating the heating circulation pump.

3.3.7 Interfaces

Supply air

Axial fan intake on RondoDry.

Exhaust air

Exhaust air outlet on RondoDry.

Heating water

Supply and return flanges on RondoDry heating module.

Substrate

Flange for substrate inlet and outlet on RondoDry or knife gate valve, if fitted.

Power

Terminal in RondoDry switch cabinet.

Description of the machine

Signal input/output

Terminal in RondoDry switch cabinet.

The eccentric screw pump(s) with Greenbox on-site control cabinet are supplied loose and must be installed by local specialists in consultation with Fliegl. The power supply to the components must be established by specialist personnel. The cables must be routed up to the RondoDry switch cabinet. The cables must be connected to the switch cabinet by trained commissioning personnel. Fliegl guarantees the functionality of the fitted components provided they are installed and used as per manufacturer specifications (see supplier documentation).

Compressed air

Connecting valve on the knife gate valves for the supply and discharge of the material to be dried.

Data on the quality of the compressed air:

ISO 8573-1:2010 [A=0(<40µm):B=7:C=4]

dirt particle size	max. 40 µm
dirt particle content	max. 10 mg/m ³
residual oil content	5 mg/m ³
pressure dew point	under minimal ambient temperature (achieved with use of refrigerant dryer)



Attention: Do not add glycol since this will dissolve the rubber seals!

3.4 Layout of the machine

The following figure provides an overview of the most important components and assemblies and shows where they are installed on the machine:

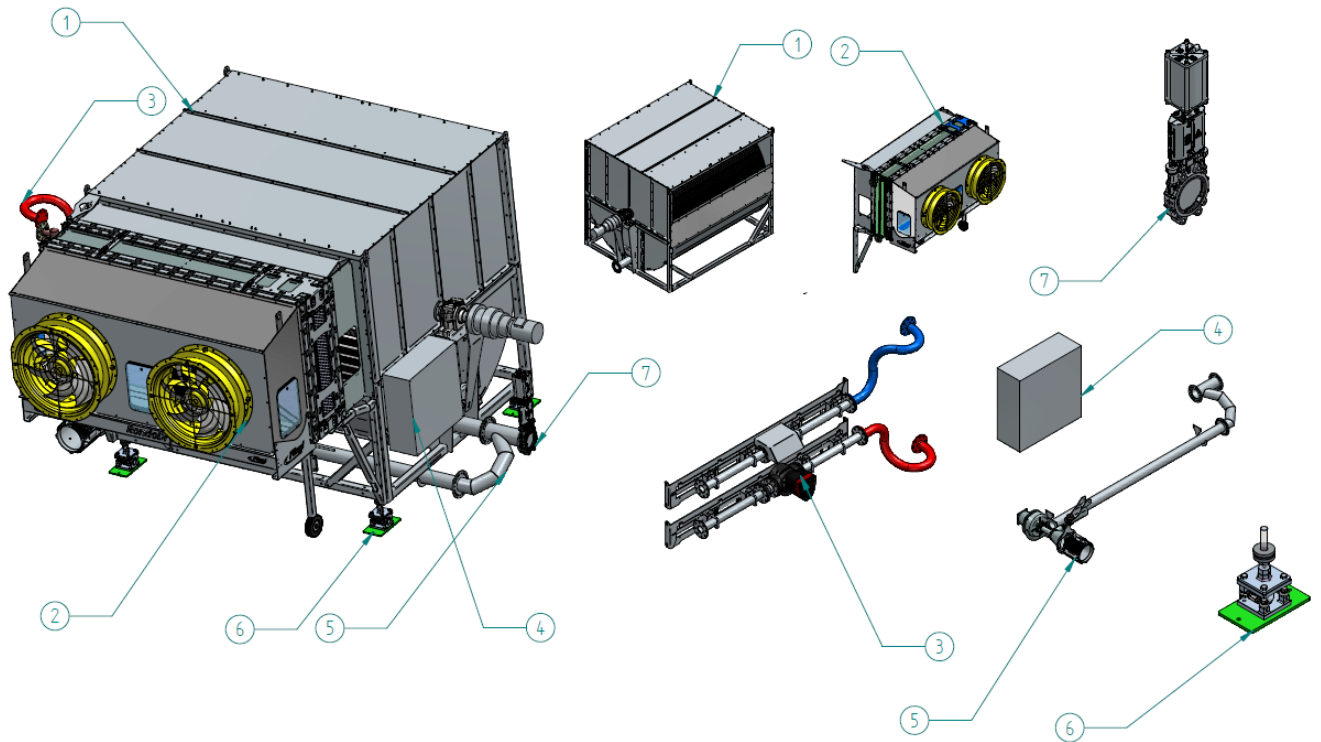

Item	Description
1	Base body + drum
2	HeatBox
3	Heating module
4	Switch cabinet
5	Purge line
6	Weighing foot with weighing sensor
7	Knife gate valve

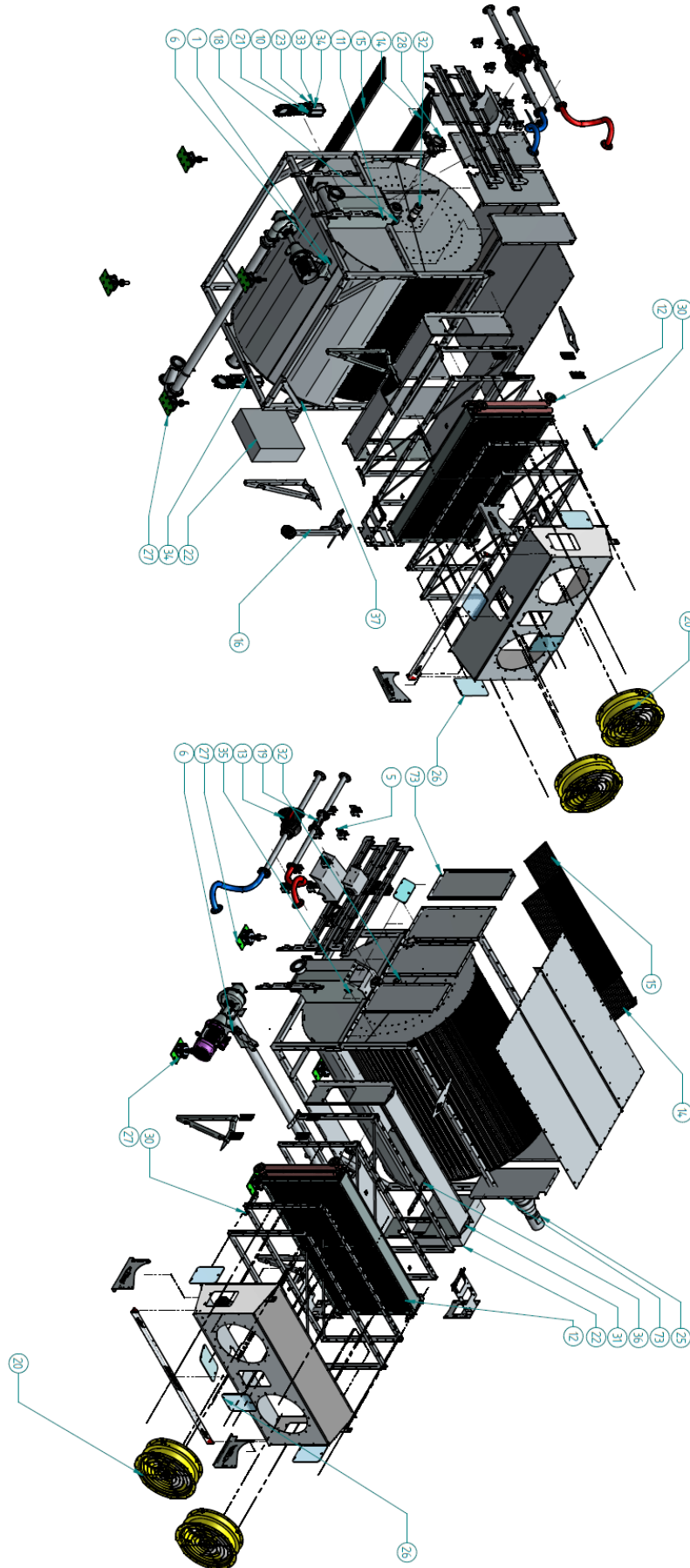

Fig. 7: Layout of the RondoDry (1)

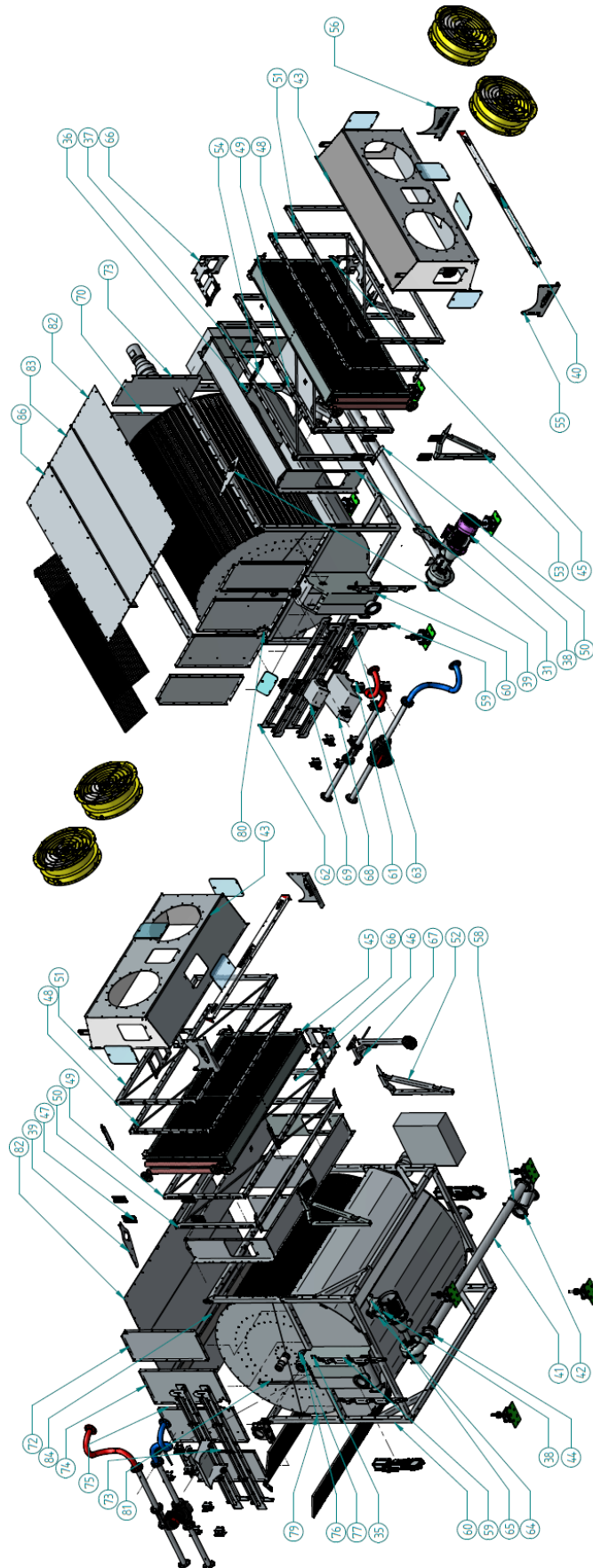

Fig. 8: Layout of the RondoDry (2) – assemblies and components

Description of the machine

Item	Description	Item	Description
1	Rubber hollow spring	44	Isolating buffer - rubber compensator
2	Straight screw-in fitting	45	Cover plate
3	Straight screw-in fitting	46	Counter piece for eccentric closure
4	Straight screw fitting	47	Folding frame hinge
5	U-bolt	48	Frame 1
6	Rubber buffer for gear unit	49	Frame 1
7	Sensor - actuator	50	Frame 2
8	Silencer	51	Frame 3
9	Straight screw-in fitting	52	Support / right
10	Angle fitting	53	Support / left
11	Vibration level switch	54	Plate / lug
12	Heat exchanger	55	Plate / left / support frame
13	Circulator pump	56	Plate / right / support frame
14	Pressure grid	57	Plate / curved / cable tray
15	Pressure grid	58	Bracket / plate
16	Supporting foot with shaft, crank, lug and axle plates	59	Square tube / cut-outs / cable guide
17	Disc, complete, for RondoDry drum	60	Base body
18	Shaft seal	61	Square tube / notch / tube holder
19	Ultrasonic heat meter	62	Plate / curved / cut-outs / tube holder
20	Axial fan	63	Plate / cut-outs / tube holder
21	Knife gate valve	64	Motor bracket
22	Switch cabinet	65	Motor bracket / plate / arm
23	5/2-way valve	66	Plate / reinforcement / curved
24	Coil	67	Support wheel
25	Planetary gearmotor	68	Plate / curved / roof
26	Inspection flap	69	Plate / curved / roof
27	Weighing foot with weighing sensor	70	Cover panel 3
28	Pedestal bearing	71	Cover panel 6
29	Torque support	72	Cover panel 1
30	Eccentric closure	73	Cover panel 4
31	Heat exchanger intermediate box	74	Cover panel 2
32	Shaft with flange	75	Cover panel 7
33	T-slot cylinder sensor	76	External PE seal
34	Mounting adapter for tie rods	77	Internal sealing disc
35	Fill level sensor for level detection	78	Lateral seal
36	Switch cabinet holder	79	Flange plate for air scrubber
37	Switch cabinet holder	80	End panel for air scrubber
38	Motor	81	Square tube / cut-outs
39	Plate / reinforcement	82	Upper cover plate 3
40	Support frame	83	Upper cover plate 1
41	Longitudinal tube	84	Tube for RondoDry seal plate
42	Round tube / elbow	85	Clamping strip for seal plate
43	Fan case	86	Upper cover plate 2

3.5 Technical data for the main components and performance data

Data	
Dimensions	
Length	4.80 m
Width	4.24 m
Height	2.91 m
Weight	
Mass in tonnes	Approx. 6.0

Drying system	
Tank capacity, approx.:	3.0 m ³
Grid surface area (evaporation area), approx.:	400 m ²
Power consumption, max. 400 V, 3~:	4.07 kW _{el}
Power consumption, optimum RondoDry operating point:	< 1.0 kW _{el}
Grid gear motor	
Power consumption at 50 Hz (target speed):	1.1 kW _{el}
Axial fans, speed-controlled	
Max. air flow rate, each:	18,000 m ³ /h
Connected load:	1.85 kW _{el}
Water/air heat exchanger	
Output power, air side, approx.:	500 kW _{th}
Flow rate, water side:	22.19 m ³ /h
Pressure loss, water side:	35.16 kPa
Centrifugal pump DGP-TRO	
Connected load:	9.2 kW _{el}
Revolutions:	1,460 rpm
Delivery rate, approx. (depending on dry mass content and viscosity):	> 120 l/min
RondoDry performance data	
Evaporation efficiency, up to:	1.0 kg/kWh _{th}
Water reduction, up to:	500 kg/h
Emissions	
Emission sound pressure level at workplace, L pAd:	64.9 dB (A)



EMC: acc. to EMC Directive and EMC standards for use in industrial applications



The evaporation efficiency depends on basic parameters such as the intake air temperature and humidity, T_{supply} on hot water side, substrate temperature. 1.055 kWh/kg water verified and examined by environmental auditor André Müller / QAL on 18/03/2016. Refer to expert report. (Separate document)

4. Transport and installation



Observe warnings!

4.1 Transporting the machine to the installation location



Must be observed; risk of serious transport damage!

4.1.1 Means of transport

The following means of transport are needed to transport the machine:

- Truck-mounted crane or similar
- Suitable lifting gear



Fig. 9: Means of transport

4.1.2 Before transport



The exact installation positions of the individual components are specified in the installation diagram or the order drawing.

- Determine the exact installation location and mark it.
- Determine the transport route and remove any obstacles.
- Keep unauthorised persons away from the transport route and set-up location. Close off the area.

4.1.3 Transporting the machine

- Attach the lifting gear for crane transport to the welded suspension eyes on the top.
- Ensure that the lifting gear does not damage any attachments.
- When working with an indoor crane, use one trolley each for the two front and two rear suspension eyes.
 - Raise the machine carefully and only slightly off the ground. Ensure that the centre of gravity is balanced.
 - If necessary, adjust the rope lengths so that the machine hangs straight on the crane.
 - Transport the machine to the installation location as close to the ground as possible.
 - Lower the machine carefully and slowly.



Help to protect our environment.
The packaging material of the machine is fully recyclable.
Please dispose of it in the correct manner.



4.2 Setting up and assembling the machine



Ensure that the machine is installed level.

4.2.1 Setup

- The machine must be set up horizontally in both directions.
- Align all components with one another according to the installation diagram or order drawing.
- Finally, use a spirit level to ensure correct installation.

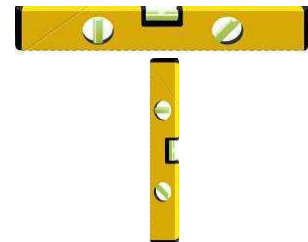

Fig. 10: Measuring aids

4.2.2 Assembly

- The machine is delivered by the manufacturer in assembled state.
- The support feet with the weighing cell are anchored in the ground with bolts.
- All cables and lines must be routed close to the machine in a cable duct or mesh cable guide.
- The machine must only be installed on solid, level ground (water-impermeable concrete).
- The machine must only be assembled and set up by specially trained personnel.
- The electrical supply must only be installed by qualified and authorised electricians.
- The water installations must only be implemented by qualified and authorised specialists.



The machine must be installed in a monitored area and the operator must ensure that no unauthorised persons are within this area.

5. Supply and installation

5.1 Overview of installations

- Substrate connection
- Power connection
- Signal cable connection
- Compressed air connection
- Heating water connection



All installations must be implemented by authorised specialist personnel. Fliegl accepts no liability for damage resulting from improper installation by external companies.



The customer is responsible for connecting additional components (e.g. air scrubber) to the RondoDry in accordance with manufacturer specifications.

5.2 Establishing electrical connections



The wiring in the switch cabinet and outside the machine must only be installed by qualified electricians.



The electrical supply is connected in the switch cabinet.

The connection must be established at the installation location according to the applicable standards and guidelines and based on the electrical circuit diagram.

For voltage and current consumption, refer to section 3.5.

5.2.1 Procedure

1. Insert the supply line into the switch cabinet via the fitting on the underside of the cabinet.
2. Connect the supply line to the labelled terminal block in the switch cabinet.
3. Check the power supply.
4. Earth the RondoDry (via the marked earthing point).



5.2.2 Connecting the components

All components must be aligned and connected as per the installation diagram (order drawing).

5.2.3 Electrical connections

- Establish the connections as shown in the electrical circuit diagram.
- Ensure that the cables do not present any trip hazards.
- Protect the cables against damage.

5.3 Water installation



The heating water connection must only be established by qualified specialists.



5.3.1 Procedure

- Route the supply lines up to the machine.
- Establish the connections as per the connecting diagrams.
- Perform a leak test.



The following attachment parts are provided separately:

- Pumps
- Gate valves

These must be installed and connected by local specialist personnel.

6. Start-up

6.1 First-time start-up



- Without a correct start-up in accordance with these operating instructions, the operational safety of the machine is not guaranteed. This can lead to accidents resulting in serious injury or death.
- All setting and adjusting tasks must be performed for first-time start-up.
- Before starting work, the operator must familiarise himself with all actuating devices and their function. It is too late to do so once work has started.
- Check the operational safety of the RondoDry before every start-up.
- Before start-up, instruct persons to leave the danger area, e.g. around drives.
- There is a risk of injury at crushing and shearing points in the area of the: Fans, as well as between the shaft and pedestal bearing
- Before starting up the machine, ensure that there are no persons in the danger area.
- Observe the safety instructions affixed to the RondoDry. An explanation of the individual warning symbols is provided in these operating instructions.
- Also comply with the instructions in the relevant sections and in the appendix of these operating instructions.

6.2 Check before start-up

The points below will facilitate machine start-up.

For more detailed information, refer to the relevant sections in the operating instructions.

Check to ensure that all safety devices (covers, panels etc.) are in proper condition and are attached to the RondoDry in protective position.

6.3 Returning to service

After an extended storage period, the same steps as for first time start-up must be completed.

See section 6.1.

6.4 Specifications for fault-free operation of the RondoDry

The specifications of the third-party component manufacturers (suppliers) apply without restriction.

More information is available under "Supplier documentation" in these operating instructions.

This applies particularly to the following components as well as to the materials that are processed or are required for operation of the components:

- Substrate pump(s): Use of separated substrate, without foreign material
- Heating circulation pump
- Heat meter
- Knife gate valve
- Heat exchanger
- DGP flushing pump
- Fans

All specified components with movable parts that come into contact with freezing media must be protected against frost!

7. Preparation and setup

7.1 Electrical system

See section 5.2



The customer is responsible for connecting additional components (e.g. air scrubber) to the RondoDry in accordance with manufacturer specifications.

7.2 Before operation

The following steps must be performed to set up and prepare the machine

- Installation of the air heater unit
- Connection of the hot water lines to the heat exchanger
- Connection of the substrate supply and discharge lines
- Connection of the compressed air lines to the knife gate valves
- Configuration of the PLC control unit
- As a rule, the initial configuration of the PLC control unit is performed by the Fliegl assembly and start-up personnel.



Assembly only by specialist personnel.

8. Use and operation



Read carefully. If there is anything you do not understand, contact the manufacturer to exclude the possibility of operating errors.

8.1 Before operation



- Instruct unauthorised persons away from the machine.
- Carry out a visual inspection of the entire machine and the tools.
- Ensure that the system is fully deactivated, i.e. the main switch (on the side of the switch cabinet) is off and the emergency stop button is pressed.
- The operator is responsible for renewing the labels if they should be lost or become unreadable.
- Otherwise, this could result in incorrect connections etc.

8.2 Switching on the machine

1. Set the switch on the side of the switch cabinet to position 1 (on).



2. Pull out the emergency stop button.



3. Press the blue reset button.



Emergency stop relay:

The switch cabinet contains a red emergency stop relay. The relay features 2 LEDs.

- Emergency stop pressed: no light
- Emergency stop released: 1st LED illuminated, press reset button

Results of reset:

- Emergency stop with 2 illuminated LEDs: system ready
- Emergency stop with 1 illuminated LED: reset unsuccessful, indicates short-circuit or overvoltage

8.3 Conducting a trial run

After the machine is set up and prepared and before work begins, a trial run must be conducted in *unloaded condition*.

8.3.1 Objective

Check to ensure the machine is set up correctly and functioning properly.



Observe the direction of rotation of all electric motors and screw conveyors.

8.3.2 Prerequisites

- Machine is ready for operation
- Machine is fully set up



Familiarise yourself with the basic safety instructions (see section 2) and the instructions for first-time start-up (see section 6.1) before the trial run and take all the safety precautions listed in these sections.

8.3.3 Procedure

- Turn on the machine as specified.
- In the main "Betriebsmodi" [Operating modes] menu, select "Hand" [Manual] mode.
 - Manual mode is intended for test purposes only and does not feature any safety functions.
 - Incorrect operation in manual mode can lead to damage.
- Perform all functions of the machine individually.
- Start the automatic cycle.
- Correct the settings if necessary.

8.4 Machine operation – procedure

- The liquid to be thickened is transferred from the final repository or upstream container into the RondoDry by means of a suitable pump.
- Alternatively, a pressure-less gravity feed is possible.
After the filling process, the slide gates before and after the device are closed.
 - The use of 2 slide gates between the storage tank and the RondoDry is recommended in this case.
- Inside the machine is a slow-rotating, cylindrical grid.
- The grid is submerged in the digestate by about a third, while the rest of the grate extends upwards out of the digestate, where it is exposed to the airflow.
- When submerged in the digestate, the surface of the grid elements is coated with a thin layer of liquid.
- The hot airflow passes through the grid elements, thereby resulting in the evaporation of part of the liquid adhering to the grid.
- The weight of the RondoDry and its contents is measured and logged by means of Fliegl weighing technology (weighing cells).
- Once the required evaporation quantity has been reached, part of the liquid in the RondoDry is discharged via the pump. The vertical grid on the underside of the drum remains fully coated.
- Following the discharge of a thickened load, the filling/thickening process restarts.

8.5 Switching off the machine

**Follow the instructions in sections 7 and 8 in reverse order.
You must also observe the safety information in sections 7 and 8.**



Note the following safety instructions during operation:

- **Risk of scalding and burns due to leaks on water lines or on the heat exchanger.**
- **Check the water lines for leaks**
- **If the machine is located outside, it must be protected against condensation and frost.**

8.6 Working with the machine

8.6.1 General safety and operating instructions

The following section contains some general notes on safety and operation for working with the RondoDry, repeated and summarised together for better clarity:

1. Always transport the machine using suitable transport means and restraints.
2. Only remove the guard plates for maintenance and servicing when the machine is switched off.
3. Always wear protective gloves when operating lever sets or slurry slide gates.
4. Note the external point of contact between the shaft and pedestal bearing as there is a risk of entanglement of the upper limbs here.
5. High injury risk for persons in the surrounding area due to the rotation of the drum with the pressure grids in the dry chamber.
6. Risk of fatal electric shock in the area of the switch cabinet and cable guides.
7. Risk of burning on the heat exchanger as well as on its supply and return lines.
8. High risk of poisoning due to production of ammonia gases when drying the digestate.
9. The machine seals must be checked on a regular basis.
10. Potential maloperation of the drying process, resulting in injury to the operator and bystanders as well as environmental damage due to pollution.
11. High risk of injury due to maloperation of the machine resulting from insufficient familiarity of the operator with the machine.
12. High risk of personal injury due to unauthorised start-up of the machine.
13. Repairs, servicing and maintenance work must only be performed when the system is de-energised and secured against reactivation.
14. The mains isolator switch must be OFF and secured against reactivation.
15. **Attention: In manual mode, opened slide gates close automatically once the maximum time for manual operation has expired.**

9. Control and display elements



The machine is operated only via the display or switch cabinet

9.1 Location of the control and display elements

The following figure provides an overview of the most important operating and display elements and shows where they are installed on the machine:

Position	Description
1	Fault light, <i>red</i>
2	Reset button, <i>blue</i>
3	Operating state light, <i>green</i>
4	EMERGENCY STOP button
5	Separates display

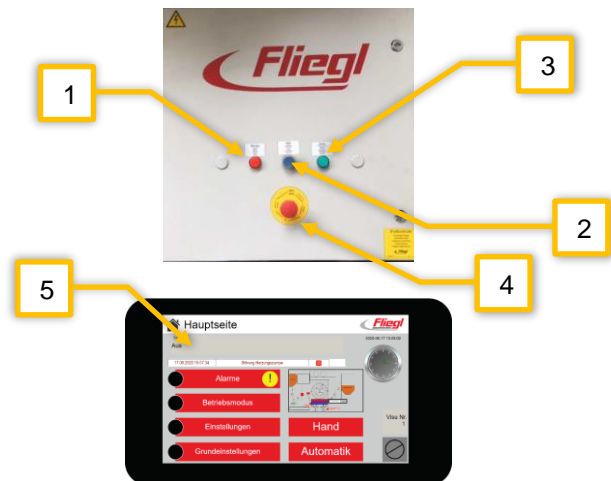

Fig. 11: Operating/display elements

9.2 Operating elements on the switch cabinet

9.2.1 Mains isolator

Switches the current supply for the machine on or off. In position 0, the mains isolator can be locked using a separate padlock.

- **Position 0:** Power supply OFF
- **Position 1:** Power supply ON



Fig. 12: Mains isolator

9.2.2 Operating element: PLC machine control unit



Fig. 13: PLC machine control unit



The latest version of the instructions for the PLC control unit is supplied with these operating instructions (also available online at: support.fliegl.com).



The version of the control unit is displayed under "Settings".

10. Equipment

10.1 Overview of the RondoDry

Description	Standard scope of delivery	Optional equipment
RondoDry with fans	X	
Heat exchanger	X	
PLC for weighing electronics incl. sensors	X	
Circulating pump for heating water	X	
Heat meter (2 x temperature, flow meter, computing unit)	X	
Eccentric screw pumps for filling and emptying		X
Gate valve, pneumatic magnetic		X

10.2 Additional components



Additional information on the components is provided in section 3.5

11. Service and maintenance

Switch off the machine and secure it against reactivation. Read the operating instructions.

Below you will find information on troubleshooting and maintenance of the machine.

Regular maintenance in accordance with the maintenance plan is essential to the efficient use of the machine.

11.1 Customer service

Please contact:

Fliegl Dosiertechnik GmbH
Bürgermeister-Boch-Straße 1
84453 Mühldorf am Inn, Germany

Tel.: +49 (0)8631 / 307 - 500

E-mail: biogas@fliegl.de

<http://support.fliegl.com/de>

11.2 Replacement parts



For a detailed list of all relevant replacement parts, please refer to the replacement parts list for the RondoDry. It can be found on the support page.

For replacement part orders, please contact:

Fliegl Dosiertechnik GmbH
Bürgermeister-Boch-Straße 1
84453 Mühldorf am Inn, Germany

Tel.: +49 (0)8631 / 307 - 500

E-mail: biogas@fliegl.de

<http://support.fliegl.com/de>



When ordering replacement parts, note also the instructions in section 1 and specify the relevant data from the type plate of your RondoDry in the order.



Additional information on replacement parts and electrical support is available at:

<http://support.fliegl.com/de>



11.3 Type plate

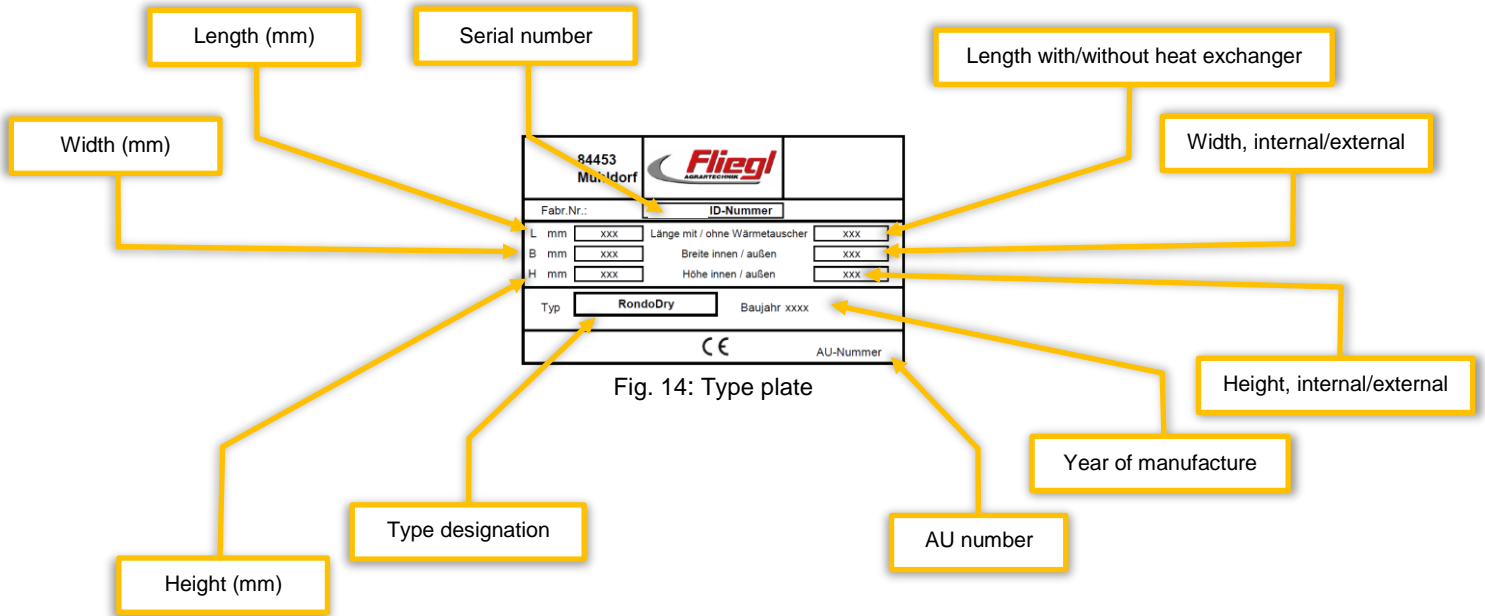

Fig. 14: Type plate

11.4 Operational maintenance

11.4.1 General instructions for maintenance

Operational maintenance helps to ensure trouble-free and efficient use of the machine. Operating personnel can perform this work after receiving appropriate instruction.

Maintenance task	Interval										Comment
	Daily	Weekly	Before maintenance work	After first 10 oper. hrs	Every 50 oper. hrs	Every 200 oper. hrs	Quarterly	After every repair	New start-up	Annually	
Inspect safety and protective devices	X							X	X		
Monitoring equipment	X										
Check that all screw joints are securely fastened				X	X						Re-tighten all loose screw joints as necessary
Check pedestal bearing for wear or cracked housing							X				
Clean the heat exchanger			X				X				Check for any damage to the fins!
Clean the fill level sensors		X	X						X		
Clean the mesh drum, tank, overflow shaft, external area							X		X		Depending on substrate composition
Weighing feet		X	X						X		Contamination can impair the weighing results
Check the pump for smooth running and leak-tightness	X										
Lubricate the lubricating points	X										
Check the oil levels of the gear units						X					Top up gear oil if necessary
Oil change										X	



Some of the above tasks depend greatly on the type of use and the ambient conditions. The cycles specified above are the minimum requirement. Different maintenance cycles may be needed in individual cases.

In this case:



- Correct the values given in these operating instructions.
- Inform operating personnel about the applicable changes.

11.4.2 Check the safety devices



All devices for stopping in an emergency must be checked individually and separately from each other. In the case of faulty safety devices, stop the machine immediately and secure it against reactivation.

11.4.3 Function test of the emergency stop equipment

1. Switch off the machine → Actuating the device for emergency stopping must cause all machine functions to be shut down:
 - Start enable
 - Motors and pumps

11.4.4 Clean the machine

Do not use any aggressive cleaning agents to clean the machine.

Procedure

1. Switch off the machine
 - It is best to use just water to clean the inside and outside of the machine; do not spray water directly onto electrical switches and components.



Repairs, servicing and maintenance work must only be performed when the system is de-energised. The mains isolator switch must be OFF and secured against reactivation.



Attention: In manual mode, opened slide gates close automatically once the maximum time for manual operation has expired. The RondoDry then switches itself to OFF.

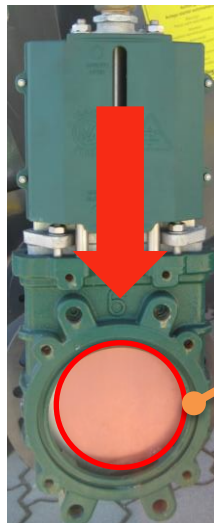

Fig. 15: Slide gate



11.4.5 Lubrication schedule

Component	Operating materials/lubricants
Lubricating points in general	Lubricating grease acc. to DIN 51 825-14 to 4 (e.g. SM11 K2E-20, L71V, FAG, ISO VG 100 or biodegradable lubricating grease CEC test L-33 T-33)
Pedestal bearing	Standard grease for bearings ISO VG 100 (-30 to +140°C)
Transmission	Mineral oil ISO VG220
Centrifugal pump	Mineral oil ISO CLP 220



Fig. 16: Oil container for lubricating the flushing pump

11.4.6 Tightening torques for screw joints

Thread	Strength class		
	8.8	10.9	12.9
M8	25 Nm	36 Nm	43 Nm
M12	85 Nm	125 Nm	145 Nm
M16	210 Nm	310 Nm	365 Nm
M20	430 Nm	615 Nm	719 Nm
M24	730 Nm	1,050 Nm	1,220 Nm
M30	1,500 Nm	2,100 Nm	2,550 Nm

11.4.7 Opening the folding frame of the HeatBox

Procedure

1. Remove the cotter pins from the relevant locking levers.
 2. Open the relevant locking levers.
 3. Fold the elements ① and ② away from component 3 **individually**. (See figure)
 4. Secure the opened components to prevent them closing.
- To close the RondoDry, complete steps 1 to 3 in reverse order.*

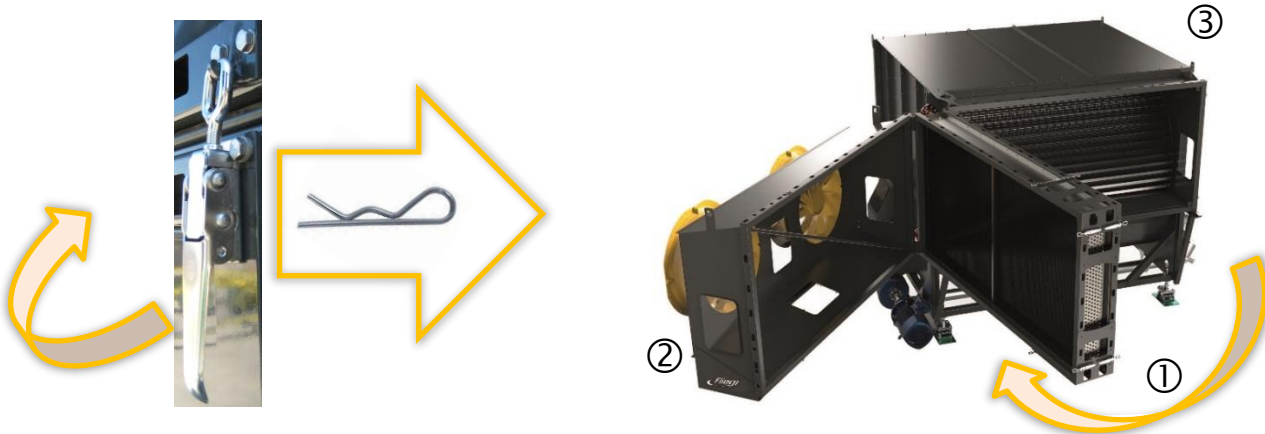

Fig. 17: Opening procedure

12. Troubleshooting and fault elimination



Special caution when rectifying faults.

- Consult trained service personnel or
- visit a specialist workshop.
- If necessary, contact the manufacturer's customer service department.

12.1 List of warning and fault signals



A full list of the warning and fault signals is provided in the control unit instructions (see 9.2.2).

Fault / error message	Possible cause(s)	Remedy
EMERGENCY STOP due to overfilling	Overfill sensor reports overfilling	Empty the machine, overfill sensor automatically deactivates message. EMERGENCY STOP must be acknowledged on the switch cabinet.
System deactivation	EMERGENCY STOP operated	Unlock the EMERGENCY STOP (once you have verified that the machine is in safe condition) and acknowledge the EMERGENCY STOP.
Filling pump fault	Pump fault, motor circuit breaker, slide gate position	Check the pump and slide gate position
Discharge pump fault	Pump fault, motor circuit breaker, slide gate position	Check the pump and slide gate position



Maintenance, repair and conversion work on the RondoDry must only be performed with the drive switched off, electrical connections disconnected and the machine secured against start-up.

12.2 Control unit activation not possible

The control unit cannot be switched on.

Possible cause	Remedy
EMERGENCY OFF triggered (overfill sensor)	Rectify fault, acknowledge EMERGENCY OFF
No power supply	Check RCD

12.3 Start activation not possible

The start enable cannot be switched on.

Possible cause	Remedy
No power supply	Check the power supply, activate the main switch
EMERGENCY STOP triggered	Rectify fault, acknowledge EMERGENCY STOP

12.4 Decommissioning

12.4.1 Temporary shutdown

Switch off the machine and all attached assemblies, disconnect the machine power supply; see section 8. Clean and maintain the machine (see section 11.4).

→ Ensure frost protection!



After a temporary shutdown, a new start-up must take place. See also section 6.3.

12.4.2 Storage conditions

For short and medium periods (up to 2 years), the machine can be stored without special measures in the ambient conditions specified in the technical data.

For long-term storage, measures must be taken to prevent corrosion.

Drain, rinse and clean the device. Drain and flush the pipelines.

Empty the heat exchanger. Risk of frost!



Empty the heat exchanger. Risk of frost!

12.4.3 Disassembly and final shutdown

- Switch off the machine.
- Disconnect the power line from the switch cabinet or disconnect the plugs, roll up the supply line cable and secure it on the machine.
- Drain the auxiliary materials.
- Disassembly of the machine is performed in the reverse order to assembly, or as described in the disassembly instructions.

12.4.4 Scrapping and recycling

Separate machine parts and electrical parts and dispose of them in the correct manner.



Separate all parts, auxiliary materials and working materials of the machine and dispose of them according to local regulations and directives.



If you have any questions about scrapping/recycling, please contact the manufacturer.

13. Additional documentation

13.1 Supplier documentation



The supplier documentation for the individual third-party components is provided as a separate document.



You can download the supplier documentation here: <http://support.fliegl.com/de>



13.1.1 List of document contents

- Eccentric screw pump
- Flushing pump
- Substrate slide gate MZ 10E
- Circulator pump
- Fans
- Heat meter
- Heat exchanger

13.2 PLC control unit



The operating instructions for the PLC control unit are provided as a separate document.



You can download the operating instructions here: <http://support.fliegl.com/de>



14. Appendix

14.1 Conversion table

The following table facilitates the conversion of specific units

Variable	SI units (metric)		Factor	Imperial units	
	Unit name	Abbreviation		Unit name	Abbreviation
Area	Hectare	ha	2.47105	Acre	acres
Volume flow rate	Litres per minute	l/min	0.2642	US gallon per minute	gpm
	Cubic metres per hour	m ³ /h	4.4029		
Force	Newton	N	0.2248	Pound-force	lbf
Length	Millimetre	mm	0.03937	Inch	in.
	Metre	m	3.2808	Foot	ft.
Power	Kilowatt	kW	1.3410	Horse power	hp
Pressure	Kilopascal	kPa	0.1450	Pounds per square inch	psi
	Megapascal	MPa	145.0377		
	Bar (non-SI)	bar	14.5038		
Torque	Newton metre	Nm	0.7376	Pound-foot	ft·lbf
			8.8507	Pound-inch	in·lbf
Temperature	Degrees Celsius	°C	°C x 1.8 + 32	Degrees Fahrenheit	°F
Speed	Metres per minute	m/min	3.2808	Feet per minute	ft/min
	Metres per second	m/s	3.2808	Feet per second	ft/s
	Kilometres per hour	km/h	0.6215	Miles per hour	mph
Volume	Litre	L	0.2642	US gallon	US gal.
	Millilitre	ml	0.0338	US ounce	US oz.
	Cubic centimetre	cm ³	0.0610	Cubic inch	in ³
Weight	Kilogramme	kg	2.2046	Pound	lbs



► **Fliegl Agrartechnik GmbH**

Bürgermeister-Boch-Str. 1

D-84453 Mühldorf a. Inn

Tel.: +49 (0) 86 31 307-0

Fax: +49 (0) 86 31 307-550

e-Mail: info@fliegl.com

We are Fliegl.